



LNG IUS Training Deck



A note on the content

- The following slides are intended to provide a basis for effective training on LNG-IUS 20 (LNG IUS), covering important topics such as clinical data, counseling, placement procedure and technical issues
- The slides are not intended to be an exhaustive resource on each topic





Introducing LNG IUS
and its mode of action



Properties of LNG-IUS 20 (LNG IUS)

The designation of LNG-IUS 20 is based on the average *in vivo* LNG release rate over the first year

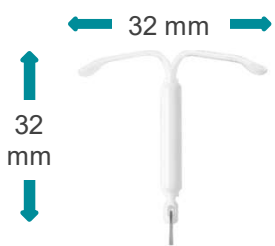
	
Maximum duration of use (years)	8
Efficacy (Pearl Index)	0.35 in Year 6
Average <i>in vivo</i> LNG release rate over the first year	20 µg/24 hours
Total LNG content (mg)	52
T-frame dimensions (mm)	32 x 32
Insertion tube diameter (mm)	4.4
Silver ring/ MR compatibility	No Silver Ring/ MR Compatible
Color of the monofilament threads	Brown

Mirena Prescribing Information. Available at: https://www.accessdata.fda.gov/drugsatfda_docs/label/2020/021225s040lbl.pdf [accessed November 2020].

Mechanisms of action

LNG-IUS mainly have a local contraceptive effect^{1,3}

Due to this local effect, plasma levels of LNG are low, meaning that ovulation is not inhibited^{1,2}

Studies of LNG IUS and similar LNG-IUS products have suggested several mechanisms that may prevent pregnancy such as¹⁻⁴:

- Thickening of cervical mucus
- Inhibition of sperm maturation/survival
- Suppressing endometrial maturation

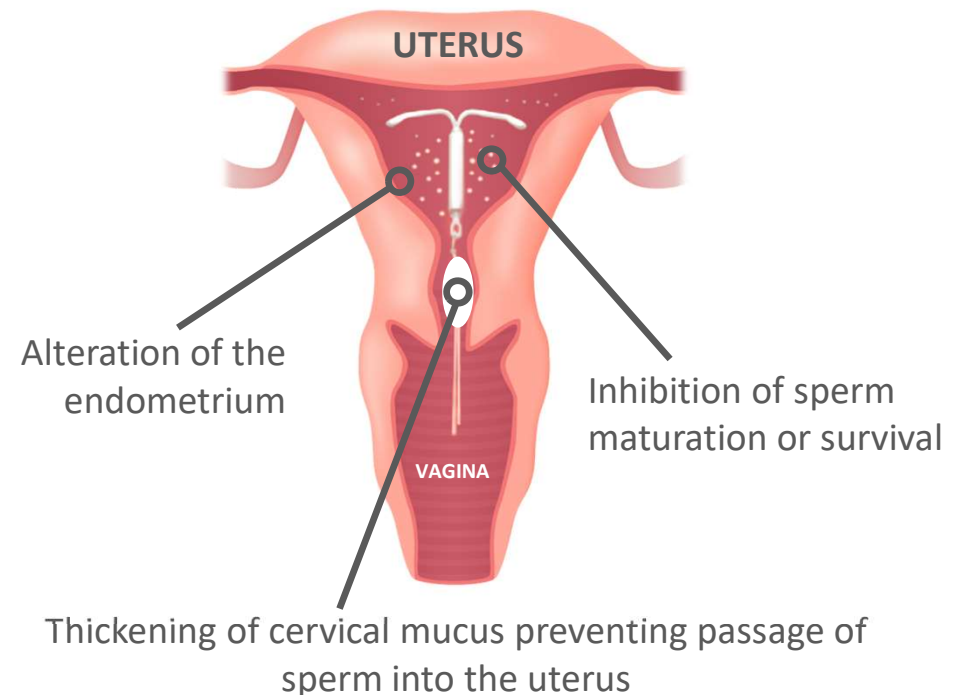

1. Stanford JB, et al. *Am J Obstet Gynecol* 2002;187:1699–708; 2. Attia AM, et al. *Patient Prefer Adherence* 2013;7:777-85; 3. Rivera R, et al. *Am J Obstet Gynecol* 1999;181(5 Pt 1):1263–9; 4. Sivin I. *Stud Fam Plann* 1989;20:355–9.

Effect on endometrium and ovaries

LNG IUS has mainly local progestogenic effects in the uterine cavity. High local levels of LNG lead to morphological changes, including^{1,2}:

- Stromal pseudodecidualization
- Glandular atrophy
- Leukocytic infiltration
- Decreased glandular and stromal mitoses

Since the contraceptive effect of LNG IUS is mainly due to its local effect, ovulatory cycles usually occur in women of fertile age

- During the first year of use, 77% of women using LNG-IUS 20 experience ovulation, increasing to 91% by year 3³

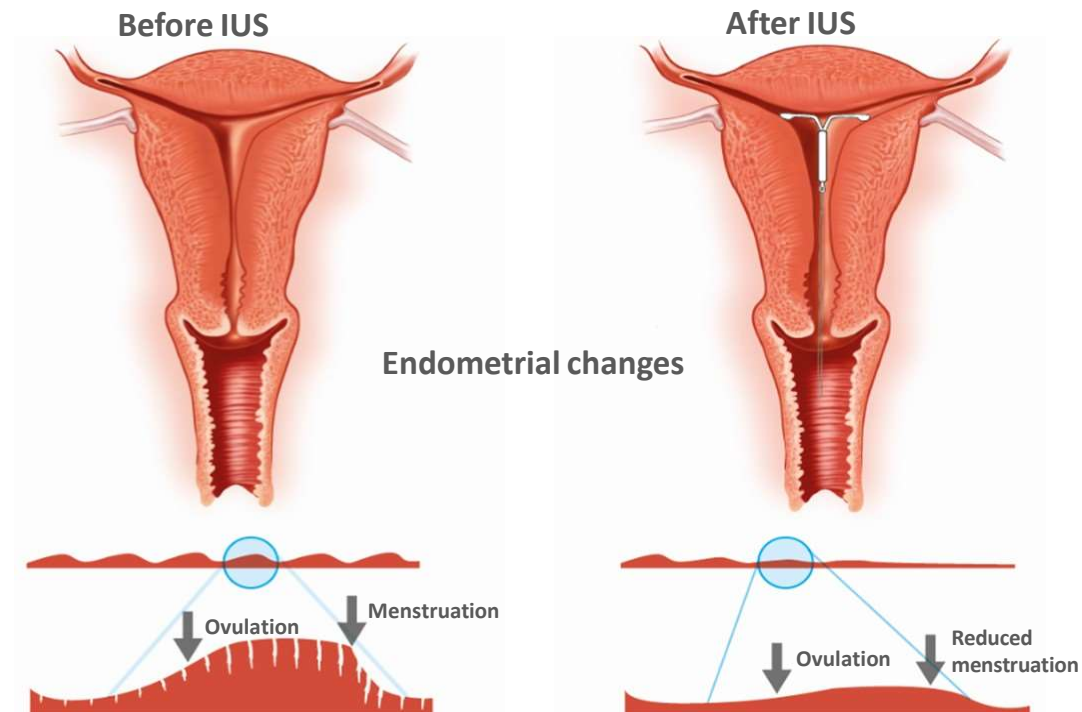

1. Attia AM, et al. *Patient Prefer Adherence* 2013;7:777-85; 2. Stanford JB, et al. *Am J Obstet Gynecol* 2002;187:1699 –708; 3. Apter D, et al. *Fertil Steril*. 2014;101;1656-62.



Pharmacokinetics of Levonorgestrel (LNG) and administration route

LNG administered via an IUS is released directly into the uterine cavity

This results in lower systemic LNG concentrations compared with transdermal routes

Mean serum LNG concentrations with LNG-IUS and implants decline steadily over time, whereas with oral contraceptives these concentrations cycle over the 21-day period of use, resulting in a high C_{max} and C_{av}

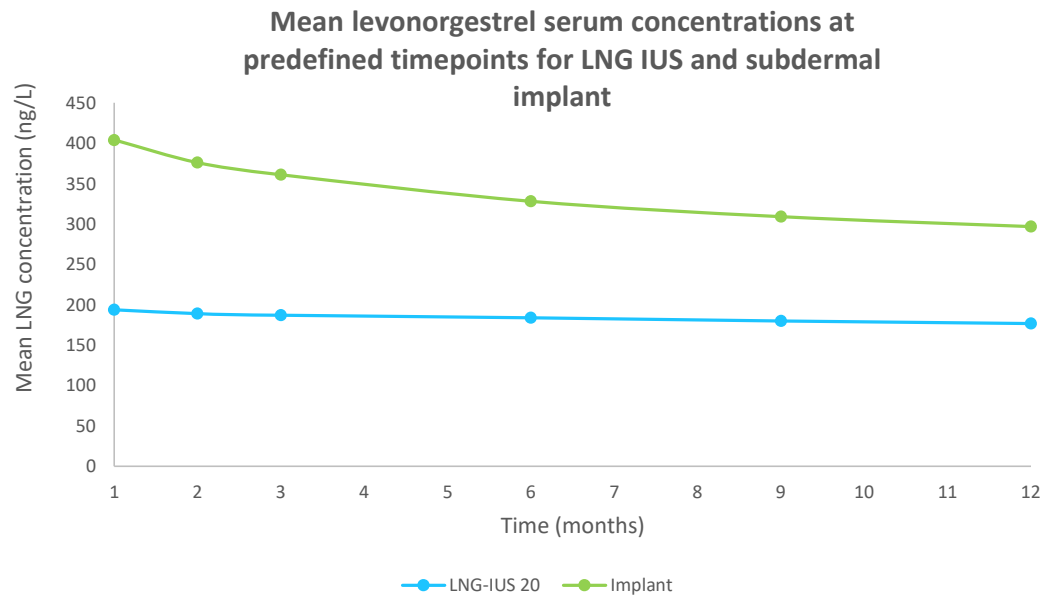

C_{av} , average concentration; C_{max} , maximum concentration
Reinecke, et al. *J Clin Pharmacol.* 2018;58(12):1639-1654.



LNG IUS clinical data



Contraceptive efficacy of LNG IUS



LNG IUS provides high contraceptive efficacy for 8 years of use, with a Pearl Index of 0.35 in Year 6⁵

1. Sivin I, et al. *Contraception* 1984;30:443–56; 2. Indian Council of Medical Research. *Contraception* 1990;42:361-78; 3. Andersson K, et al. *Contraception* 1994;49:56-42; 4. Sivin I, et al. *Contraception* 1990;42(4):361-378; 5. Mirena Prescribing Information. Available at: https://www.accessdata.fda.gov/drugsatfda_docs/label/2020/021225s040lbl.pdf [accessed November 2020].



Continuation and satisfaction rates with LNG IUS

The continuation rate for LNG IUS users is over 90% at 1 year after placement and 65% at 5 years.^{1,2} These rates compare favorably with continuation rates observed with other forms of contraception.³

Around 90% of LNG IUS users report they are very satisfied or rather satisfied.²

This is higher than reported satisfaction* with Copper IUDs (80%), implants (79%) and oral contraceptives (54%).³

Continuation rates at 1 year for different contraceptives (%)

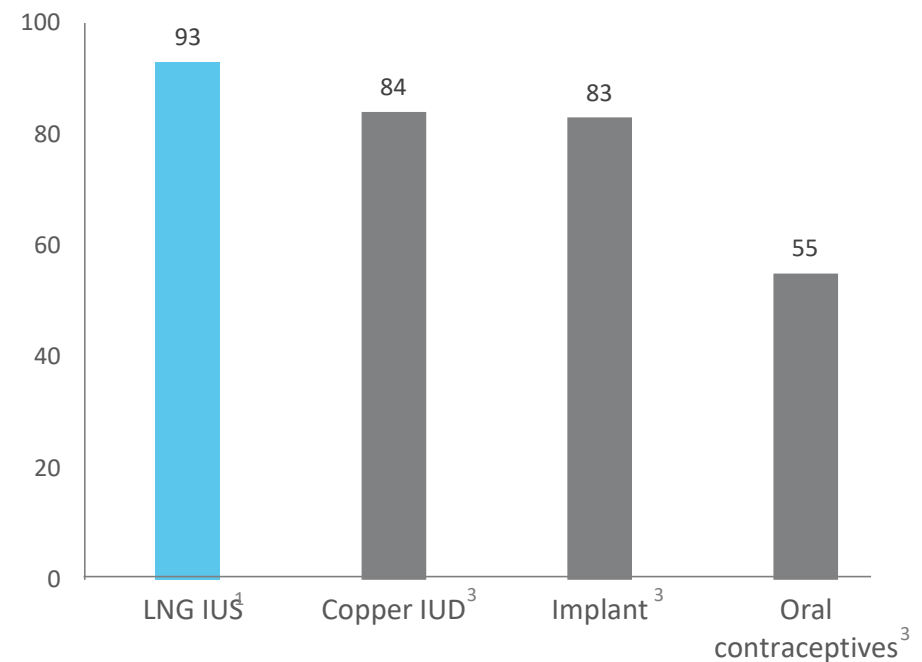

*Reported as very satisfied or somewhat satisfied

1. Backman T, et al. *BJOG*. 2000;107:335-339; 2. Zhao S, et al. *Patient Prefer Adherence*. 2014 Oct 23;8:1449-55; 3. Peipert J, et al. *Obstet Gynecol* 2011;117:1105-13.



Bleeding pattern with LNG IUS

LNG IUS users experience a significant decrease in the average number of menstrual bleeding days^{1,2} and blood loss^{3,4}

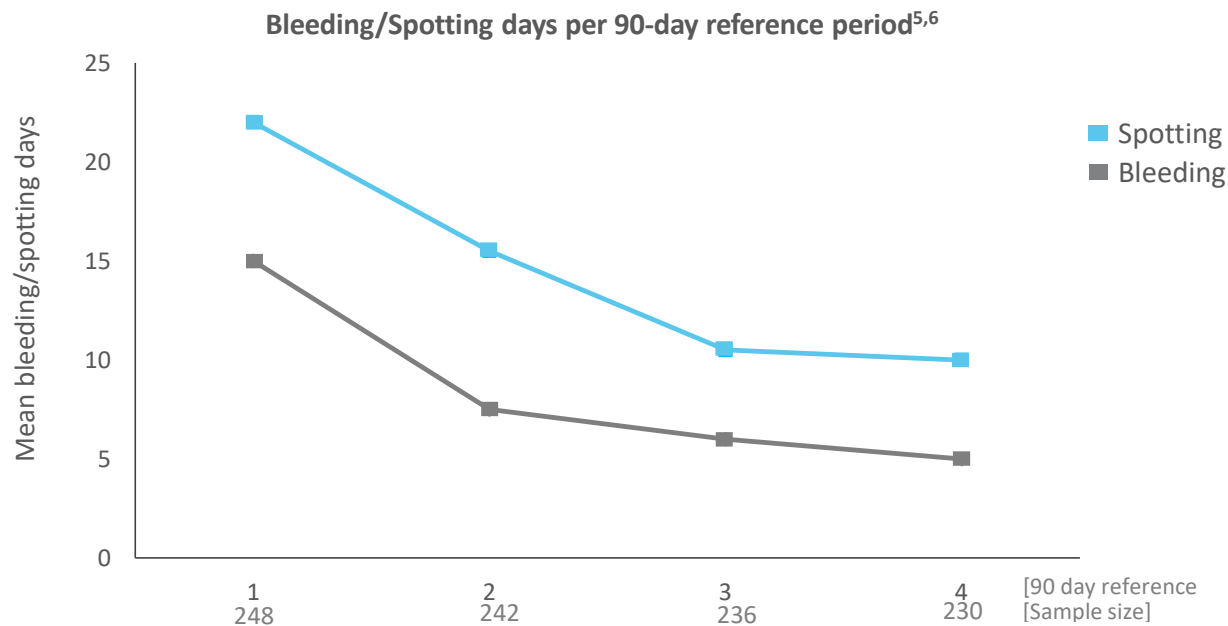

23.6%
of women experience
amenorrhea at the end of 3
years⁵
During continued use up
to 5 years, the amount
of amenorrhea
increases

1. Andersson K, et al. *Contraception* 1994; 49:56; 2. Suvisaari J1, Lähteenmäki P. *Contraception* 1996;54(4):201-8; 3. Lethaby A, et al. *Cochrane Database Syst Rev* 2015;(4):CD002126; 4. Majoribanks, et al. *Cochrane Database Syst Rev* 2016;(2):CD003855; 5. Gemzell-Danielsson K, et al. *Fertil Steril* 2012;97:616-22; 6. Maldonado LY, et al. *Am J Obstet Gynecol* 2019;doi:10.1016/j.ajog.2019.09.044.



Return to fertility with LNG IUS

Of 138 women who had LNG IUS removed due to desire for pregnancy...



This is slightly lower than reports from women discontinuing barrier methods or using no contraception (85–94%)²

1. Andersson K, et al. *Contraception* 1992; 45: 575–84; 2. Girum T & Wasie A. *Contraception* 2018;3:9.

Safety and tolerability of LNG IUS

LNG IUS use has no clinically relevant effects on:

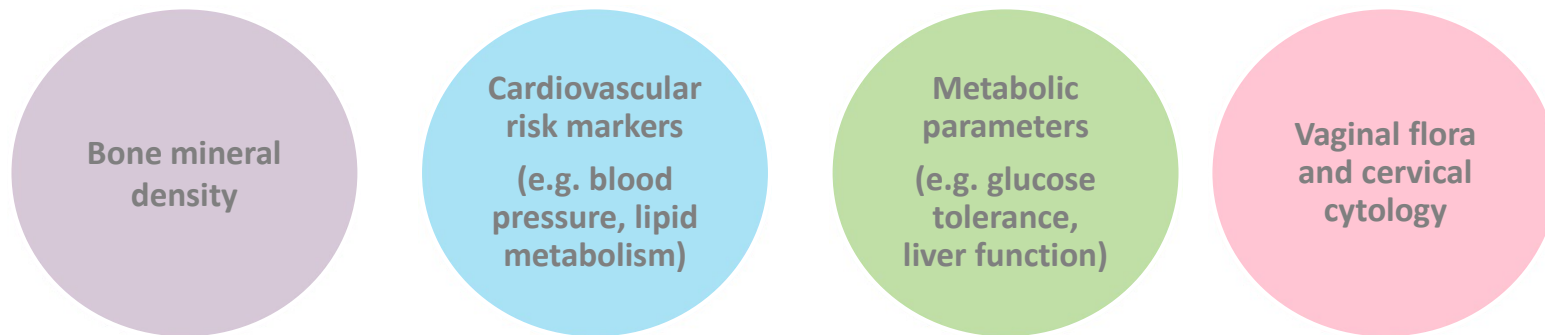

In addition, LNG IUS use has:

- No association with an increased risk of breast cancer in women aged <50 years, based on epidemiological studies
- A neutral effect on sexual function

Gemzell-Danielsson K, et al. *Acta Obstet Gynecol Scand* 2011; 90: 1177–88.



Common adverse reactions with LNG IUS

Most common adverse reactions (reported in $\geq 5\%$ users) are:

	LNG IUS (N=5091)
Abdominal/pelvic pain	22.6%
Headache/migraine	16.3%
Genital discharge	14.9%
Increased bleeding	11.9%*
Vulvovaginitis	10.5%
Ovarian cyst	7.5%
Breast pain/discomfort	8.5%
Back pain	7.9%
Acne/seborrhea	6.8%
Dysmenorrhea/uterine spasm	6.4%
Depression/depressive mood	6.4%

Teach patients to **recognise and report** signs or symptoms of these conditions.

Evaluate patients **4 to 6 weeks after placement** and then yearly or more often if clinically indicated.

*Increased scheduled uterine bleeding reported for LNG IUS users. Unscheduled uterine bleeding was also reported in LNG IUS users (31.9%) Mirena Product Monograph.



LNG IUS and HMB

Heavy menstrual bleeding overview



Heavy menstrual bleeding (HMB) is defined as excessive menstrual blood loss which interferes with a woman's physical, emotional, social, and material quality of life, and which can occur alone or in combination with other symptoms^{1,2}

- Regular menstrual blood loss exceeding 80 mL per cycle is considered to be heavy³



Heavy menstrual bleeding affects up to 30% of women at some point in their life,^{1,4} and can be a source of apprehension, embarrassment and inconvenience. Continued heavy menstrual bleeding can also lead to iron-deficiency anemia if left untreated

1. Munro M, et al. *Br J Obstet Gynecol* 2017;124:185–89; 2. National Institute for Health and Clinical Excellence. Clinical Guideline 88. Issue date March 2018. Available at: <https://www.nice.org.uk/guidance/ng88> (Accessed March 2021); 3. Warner PE, et al. *Am J Obstet Gynecol* 2004; 190: 1216–23; 4. Singh S, et al. *J Obstet Gynecol Can* 2013;35(5 esuppl);S1–S28.



Causes of heavy menstrual bleeding

The 'PALM-COEIN' classification system defines nine categories to describe the causes of abnormal uterine bleeding:

PALM

(structural abnormalities)

Polyp

Adenomyosis

Leiomyoma

Malignancy and hyperplasia

COEIN

(non-structural abnormalities)

Coagulopathy

Ovulatory dysfunction

Endometrial

Iatrogenic

Not otherwise classified

Munro MG, et al. *Int J Gynecol Obstet* 2018;143:393–408.

Guidelines recommend LNG IUS for the treatment of heavy menstrual bleeding



National Institute for Health and Clinical Excellence (NICE) guidelines:

Recommendation	Clarification
Consider LNG IUS as the first treatment for heavy menstrual bleeding (HMB) in women with:	<ul style="list-style-type: none">• no identified pathology• fibroids* less than 3 cm in diameter, which are not causing distortion of the uterine cavity• suspected or diagnosed adenomyosis*
If a woman with HMB declines LNG IUS or it is not suitable, consider the following pharmacological treatments:	<ul style="list-style-type: none">• non-hormonal: tranexamic acid, NSAIDs (non-steroidal anti-inflammatory drugs)• hormonal: combined hormonal contraception, cyclical oral progestogens.

* Note: LNG IUS is only approved for the treatment of HMB with no identified pathology (also termed idiopathic menorrhagia)
Fibroids and adenomyosis are not approved indications for LNG IUS

National Institute for Health and Clinical Excellence. Clinical Guideline 88. Issue date March 2018. Available at: <https://www.nice.org.uk/guidance/ng88> (Accessed March 2021).



LNG IUS for treatment of heavy menstrual bleeding

LNG IUS significantly reduces menstrual blood loss from as early as 3 months after placement

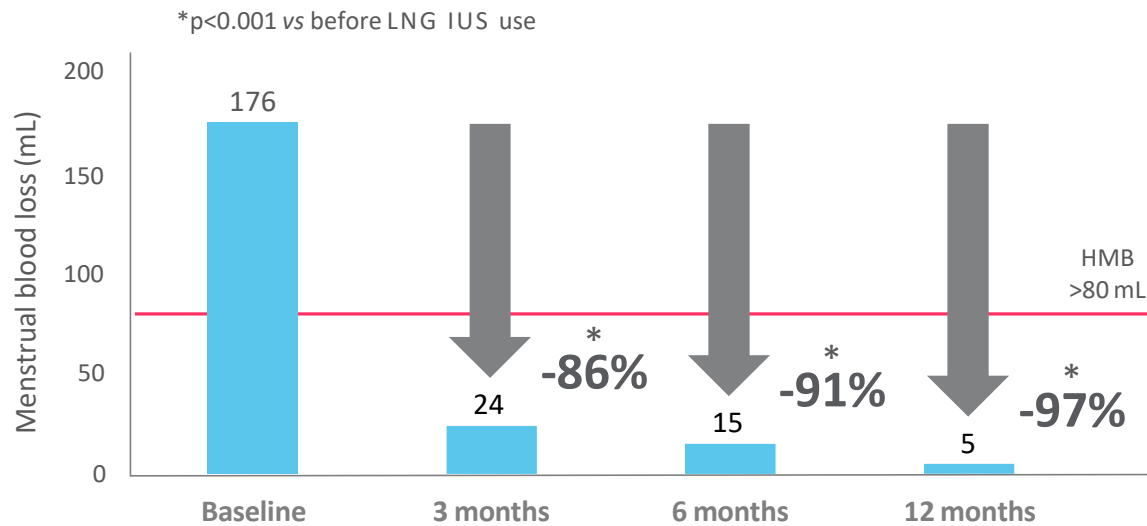

Andersson JK & Rybo G. *Br J Obstet Gynaecol* 1990; 97: 690-94.



Reductions in menstrual blood loss over five years of LNG IUS use

Pooled data from 5 studies of LNG IUS in HMB show significant reduction in menstrual blood loss of up to 96% after 5 years

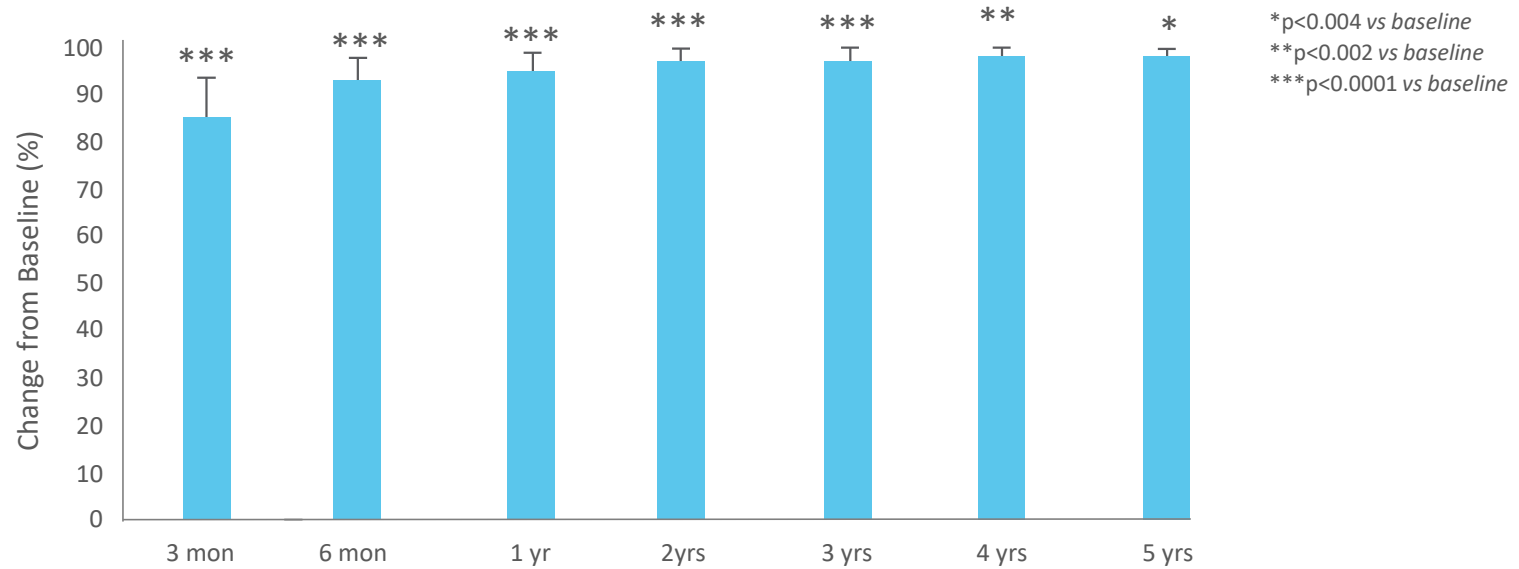

Median decrease (%) of MBL from baseline to 5 years of treatment (n=230)
Endrikat J, et al. *Arch Gynecol Obstet.* 2012;285:117–21.

LNG IUS as an alternative to hysterectomy



LNG IUS shows comparable, statistical improvements in quality of life when compared with hysterectomy

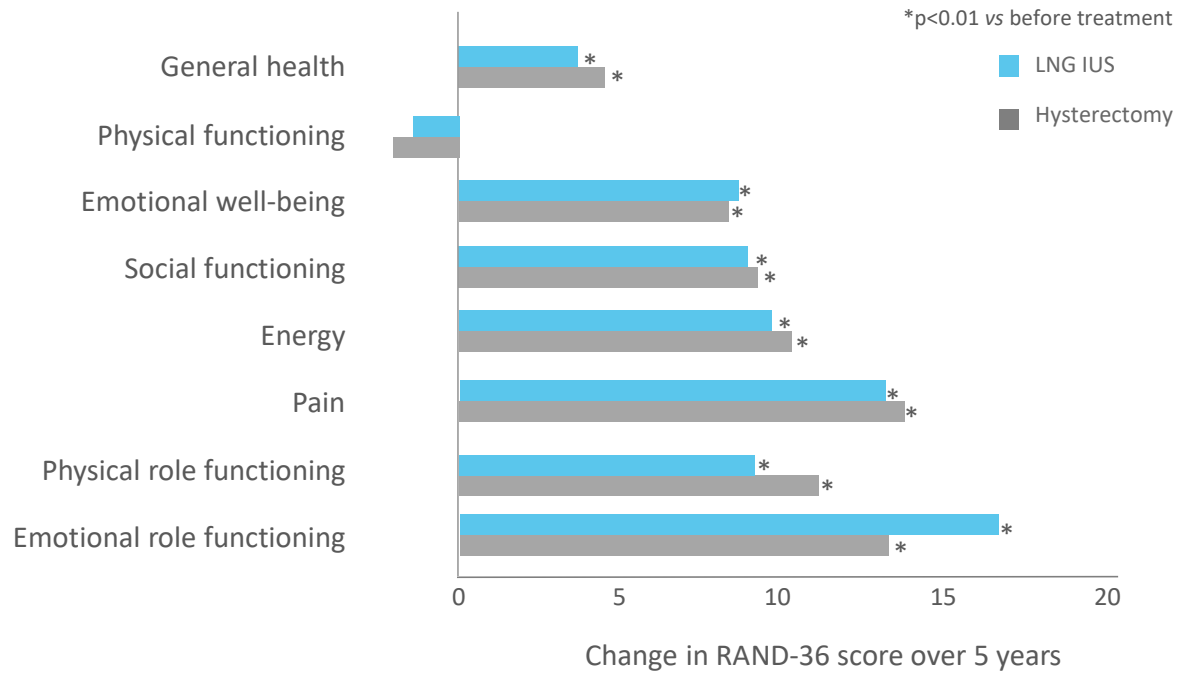

Hurskainen R, et al. *JAMA* 2004;291:1456-63



LNG IUS vs other medical therapies for heavy menstrual bleeding

LNG IUS is more effective than tranexamic acid, mefenamic acid, combined estrogen-progestogen, or progesterone alone in reducing the effect of HMB on women's daily life

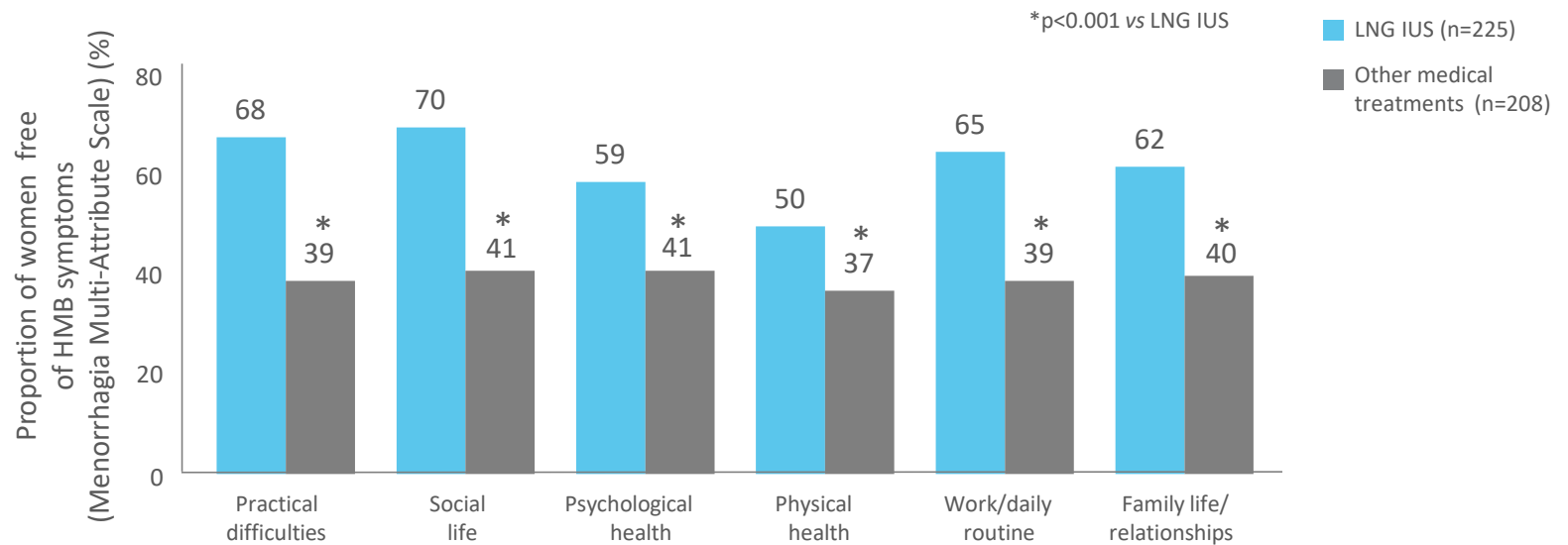

Other treatments include: Tranexamic acid, mefenamic acid, combined oestrogen-progestogen, or progesterone alone
Gupta J, et al. *N Engl J Med* 2013;368:128-37.



LNG IUS vs endometrial ablation for heavy menstrual bleeding

LNG IUS is equally effective as endometrial ablation in reducing menstrual blood loss for up to 2 years after treatment for HMB

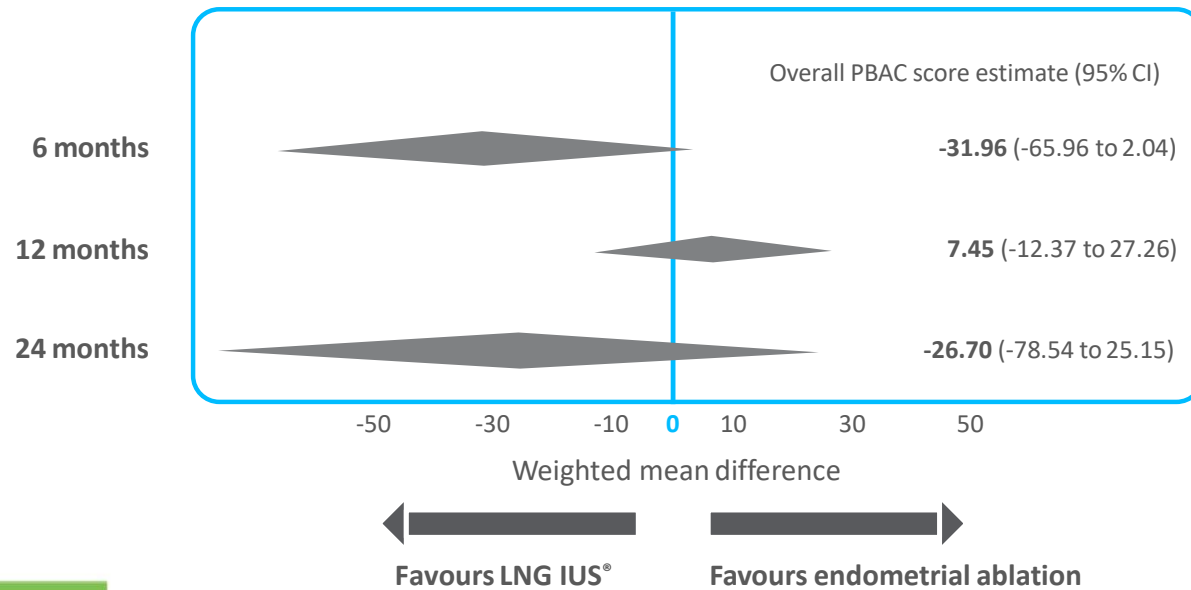

Kaunitz AM, et al. *Obstet Gynecol* 2009;113:1104–16.

Efficacy of LNG IUS for increasing hemoglobin and ferritin levels in women with heavy menstrual bleeding



Use of LNG IUS is associated with a significant increase in levels of serum hemoglobin and ferritin in women with heavy menstrual bleeding

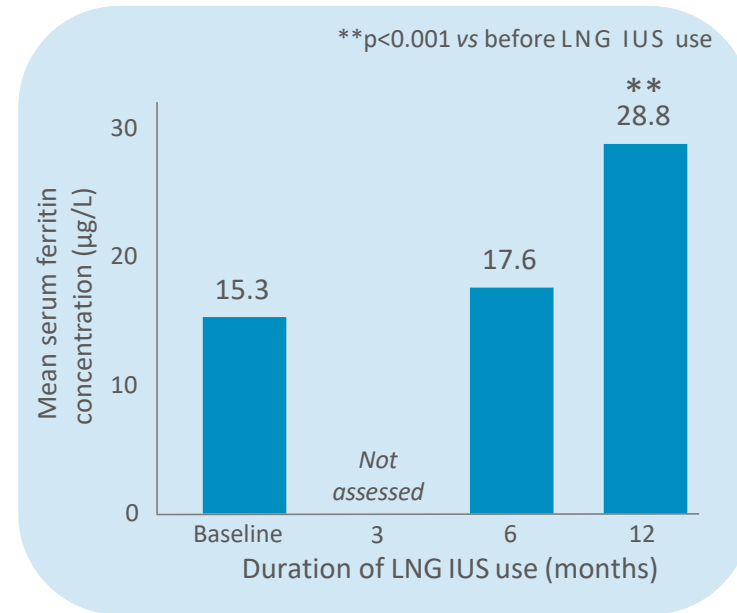
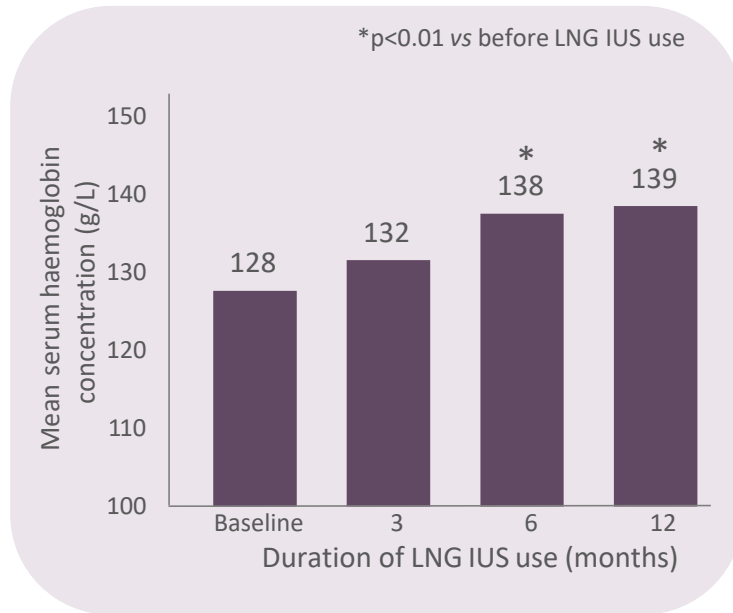

Andersson JK & Rybo G. *Br J Obstet Gynaecol* 1990;97:690–94.



Medical Eligibility
Criteria (MEC) &
important
safety information



WHO Medical Eligibility Criteria for LNG-IUS

Condition	Category	Clarification
Post-partum (≥ 4 weeks)	1	
Post-abortion (1 st trimester)	1	IUS can be placed immediately after first-trimester spontaneous or induced abortion.
Past ectopic pregnancy	1	
History of pelvic surgery	1	
Adequately controlled or moderately high hypertension	1	Moderately high hypertension = systolic <160 mm Hg, diastolic <100 mm Hg.
Obesity or smoking	1	
Non-migrainous headaches (even if severe)	1	Any new or marked changes in headaches should be evaluated.
Irregular, non-heavy menses	1	
Depressive disorders	1	Potential drug interaction with certain antidepressants.
Endometriosis	1	
Benign ovarian tumors (including cysts)	1	
Dysmenorrhea (even if severe)	1	

- 
- 1. No restriction to use
 - 2. Advantages generally outweigh the risks
 - 3. Risks generally outweigh the advantages
 - 4. Unacceptable health risk

WHO Medical Eligibility Criteria, 15th edition. Available at https://apps.who.int/iris/bitstream/handle/10665/172915/WHO_RHR_15.07_eng.pdf;jsessionid=479865AEA15B07E7E73CE1C61D7A54DA?sequence=1 (Accessed 29 Jul 2019)



WHO Medical Eligibility Criteria for LNG-IUS

Condition	Category	Clarification
Age		
- Menarche to <20 years	2	Risks of pregnancy, infection and perforation are low among IUS users of any age. Heavy bleeding or removals for bleeding do not seem to be associated with age.
- ≥ 20 years	1	
Parity		
- Nulliparous	2	Risks of pregnancy, infection, perforation and expulsion are low among all IUS users, and differences by parity may not be clinically meaningful. Data do not suggest increased delay in return to fertility for nulliparous users.
- Parous	1	
Post-partum (<48 hours)	1/2	If breastfeeding, category is 2. If not, category is 1.
Anatomical abnormalities without uterine distortion	1/2	Uterine fibroids without distortion have risk category of 1. Other abnormalities (such as cervical stenosis or lacerations) have risk category of 2.
Heavy or prolonged bleeding	1/2	Category 1 for initiation and 2 for continuation of IUS use. Data suggests IUS may be beneficial for treatment of menorrhagia.
Post-abortion (2 nd trimester)	2	
Inadequately controlled or very high hypertension	2	Very high hypertension = systolic ≥160 mm Hg, diastolic ≥100 mm Hg.
Stroke	2	

- 
1. No restriction to use
 2. Advantages generally outweigh the risks
 3. Risks generally outweigh the advantages
 4. Unacceptable health risk

WHO Medical Eligibility Criteria, 15th edition. Available at https://apps.who.int/iris/bitstream/handle/10665/172915/WHO_RHR_15.07_eng.pdf;jsessionid=479865AEA15B07E7E73CE1C61D7A54DA?sequence=1 (Accessed 29 Jul 2019)



WHO Medical Eligibility Criteria for LNG-IUS

Condition	Category	Clarification
Migraine	2/3	Any new or marked changes in headaches should be evaluated. If aura is present, risk is category 3. If there is no aura, risk is category 2.
Ovarian cancer	2/3	Category 3 for initiation of IUS and category 2 for continuation of IUS.
Increased risk of STIs	2/3	While many women at risk of STIs can generally have an IUS, some at increased risk (very high individual likelihood) should generally not have an IUS placed until appropriate testing and treatment have been carried out.
Liver tumors or severe cirrhosis	2/3	Risk category is 2 for focal nodular hyperplasia and 3 for hepatocellular adenoma, malignant (hepatoma) and severe cirrhosis.
HIV	2/3	Category 3 for initiation of IUS and category 2 for continuation of IUS. Users with severe or advanced HIV clinical disease should be closely monitored for pelvic infection. Category is 2 if HIV is asymptomatic or mild.
Post-partum (≥48 hours <4 weeks)	3	
Acute DVE/PE	3	
Past breast cancer with no evidence of disease for 5 years	3	

- 
1. No restriction to use
 2. Advantages generally outweigh the risks
 3. Risks generally outweigh the advantages
 4. Unacceptable health risk

WHO Medical Eligibility Criteria, 15th edition. Available at https://apps.who.int/iris/bitstream/handle/10665/172915/WHO_RHR_15.07_eng.pdf;jsessionid=479865AEA15B07E7E73CE1C61D7A54DA?sequence=1 (Accessed 29 Jul 2019)



WHO Medical Eligibility Criteria for LNG-IUS

Condition	Category	Clarification
Unexplained vaginal bleeding	2/4	Risk category is 4 at initiation of IUS and 2 for continuation. Should be evaluated and risk category thus adjusted.
Endometrial or cervical cancer	2/4	Risk category is 4 at initiation of IUS and 2 for continuation.
Current STIs	2/4	Current purulent cervicitis, gonorrhoea or chlamydia has an initiation risk category of 4 and a continuation risk category of 2. Other STIs (excluding HIV/hepatitis) and vaginitis have category 2.
Current or past pelvic inflammatory disease	2/4	Risk category is 4 for initiation of IUS with current PID and 2 for continuation of IUS with current PID or use of IUS with past PID.
Pregnancy	4	Not indicated for pregnancy. Should not be used due to risk of septic abortion and serious infections.
Distortion of uterine cavity	4	Distortion may be due to factors such as uterine fibroids or cervical congenital abnormalities.
Puerperal sepsis	4	
Post-septic abortion	4	
Current breast cancer	4	

- 
- 1. No restriction to use
 - 2. Advantages generally outweigh the risks
 - 3. Risks generally outweigh the advantages
 - 4. Unacceptable health risk

WHO Medical Eligibility Criteria, 15th edition. Available at https://apps.who.int/iris/bitstream/handle/10665/172915/WHO_RHR_15.07_eng.pdf;jsessionid=479865AEA15B07E7E73CE1C61D7A54DA?sequence=1 (Accessed 29 Jul 2019)



Pregnancy-related risks and ectopic pregnancy

If pregnancy should occur with LNG IUS in place, **immediately remove the intrauterine system** because leaving it in place may increase the risk of spontaneous abortion and pre-term labor.

- Removal or manipulation may result in pregnancy loss

Evaluate women for ectopic pregnancy because the likelihood of a pregnancy being ectopic is increased with LNG IUS.

- The possibility of ectopic pregnancy should be considered if the woman reports lower abdominal pain, especially in connection with missed periods, or if an amenorrheic woman starts bleeding
- Women with a previous history of ectopic pregnancy, tubal surgery or pelvic infection have a higher risk of ectopic pregnancy.

The **absolute risk of ectopic pregnancy in IUS users is low**, between 0.1–0.2% per year. This is lower than the rate of 0.3–0.5% in women using no contraception at all.

- However, if a woman becomes pregnant with an IUS in situ, the relative likelihood of ectopic pregnancy is increased





Serious complications: Pelvic Inflammatory Disease (PID)

Pelvic infections may have serious consequences and may impair fertility and increase the risk of ectopic pregnancy.

PID is generally observed more frequently at the beginning of IUS use, the highest rate of PID occurs during the first 3 weeks after placement and decreases thereafter.

- There is around a 6-fold increase in risk of PID in the first 20 days after placement.
- The overall PID risk with Bayer IUS ranges from 0.4–0.6%.

A **full evaluation for risk factors** associated with pelvic infection (e.g. multiple sexual partners, sexually transmitted infections, prior history of PID, etc.) should be conducted before placing an IUS.

If a woman experiences recurrent endometritis or pelvic inflammatory disease or if an acute infection is severe or does not respond to treatment, the IUS must be removed.

Mirena Product Monograph; FSRH Clinical Guidance (intrauterine contraception). Available at: <https://www.fsrh.org/standards-and-guidance/documents/ceuguidanceintrauterinecontraception/> (Accessed December 2019).



Serious complications: Sepsis

Severe infection, or sepsis, including Group A streptococcal sepsis (GAS), have been reported following placement of LNG-IUS.

Aseptic technique during placement of the IUS is essential in order to minimise serious infections such as GAS.

LNG IUS SmPC; FSRH Clinical Guidance (intrauterine contraception). Available at: <https://www.fsrh.org/standards-and-guidance/documents/ceuguidanceintrauterinecontraception/> (Accessed December 2019).



Serious complications: Perforation

Perforation (total or partial, including penetration/embedment of the IUS into the uterine wall or cervix) most often occurs during placement, although may not be detected until some time later.

Perforation may reduce contraceptive efficacy.

- If perforation occurs, locate and remove the IUS; surgery may be required.

The risk of perforation may be increased if inserted when the uterus is not completely involuted or fixed retroverted.

Placement up to 36 weeks after giving birth or while breastfeeding are associated with an increased risk of perforation.

Barnett C, et al. *Eur J Contracept Reprod Health Care* 2017;22(6):424-8.



Serious complications: Expulsion

The **risk of expulsion is around 1 in 20** and occurs most commonly in the first year of use, particularly within 3 months of placement.

Partial or complete expulsion of an IUS **may result in a loss of contraceptive protection.**

- Partially expelled IUS should be removed.
- A new IUS can be inserted whenever the provider is reasonably certain that the woman is not pregnant.

Placement should be delayed a minimum of 6 weeks or until uterine involution is complete following a delivery or a second trimester abortion.

Definition: Partial Expulsion

An intrauterine device protruding from the external cervical os, or a transvaginal ultrasound showing the distal end of the intrauterine device below the internal os of the cervix.



Counseling on LNG IUS



Steps to successful needs-based counseling

- ✓ Discuss **contraceptive needs**
E.g. Does she desire short- or long-term pregnancy prevention?
- ✓ Ask about **lifestyle demands**
E.g. What would the consequences of unintended pregnancy be for her?
- ✓ Discuss any **concerns or need for additional information**
Answer questions in a positive, reaffirming way

- ✓ **Review and prioritise** the most **important aspect of contraception**
- ✓ Agree a **short-list of methods** to check **for medical suitability**

‘In our practice we have a **large number** of women using this method’

‘There are many **myths associated with IUS**, let me tell you some of the real facts which may help...’



How to approach counseling on IUS

Tailor your discussion to the **needs of your patient** to identify the most appropriate choice for her as an individual – IUS won't be a suitable choice for everyone

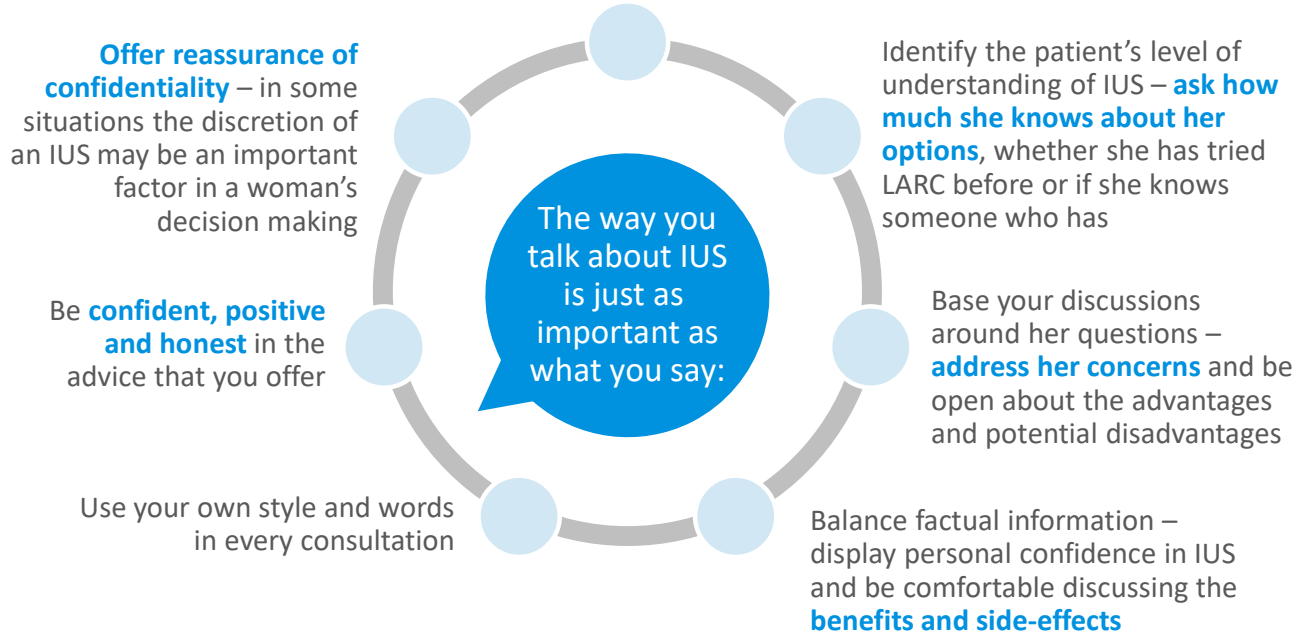

Steps to successful counselling. Available at: https://www.your-life.com/static/media/pdf/educational-material/Booklet_Simple_steps_to_successfully_counselling_women_about_IUC.PDF (Accessed March 2020)



IUS counseling checklist

Proper counseling increases patient satisfaction¹, avoids unnecessary removals and improves continuation rates²

Counseling Checklist

- 1 Mode of action, benefits and risks
 - 2 Satisfaction and continuation
 - 3 Reassurance on the size of device despite size of packet
 - 4 What to expect during placement
 - 5 Management of pain
 - 6 Possible side effects after placement
 - 7 Effect on bleeding profile after placement
 - 8 Return to fertility
-

1. Backman T, et al. *Obstet Gynecol* 2002; 99: 608–13; 2. Backman T, et al. *Eur J Contracept Reprod Health Care* 2001;6(Suppl 1): 23–6.



1. Mode of action, benefits and risks of IUS

When a woman has chosen an IUS, it is important to make sure that she understands the method and how it works, as well as the benefits and possible risks.

Presenting the facts in a calm and balanced way can help.

Some women may not be aware of how the method works, or may have misperceptions regarding its efficacy and safety^{1,2}, make sure to listen to these and answer any questions she may have.

As with any method of contraception, there are some benefits and risks to consider

1. Buhling KJ, et al. *Eur J Contracept Reprod Health Care*. 2014;19:448–456; 2. Hladky KJ, et al. *Obstet Gynecol*. 2011;117:48–54.



2. Satisfaction and continuation with IUS

In the contraceptive CHOICE study...

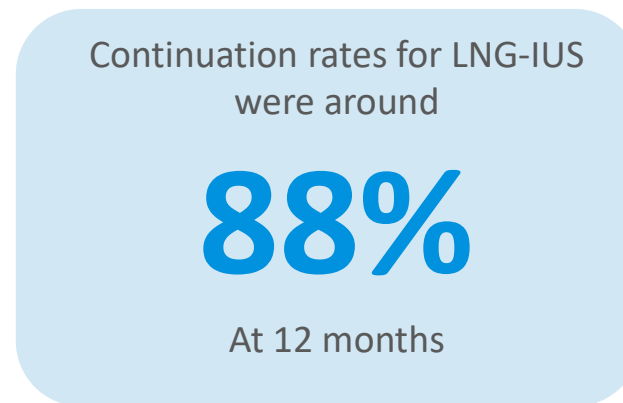
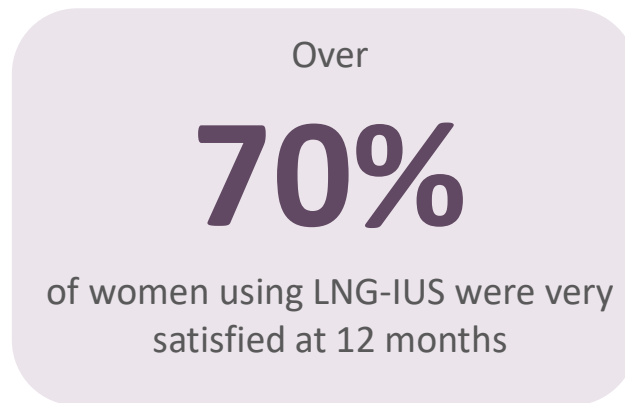

This compares favorably with other contraceptive methods such as oral contraceptives, where satisfaction* and continuation rates at 12 months were 41% and 55%, respectively

*Women reporting they were 'very satisfied' with their method
LNG-IUS users, n=1890; Oral contraceptive users, n=478
Peipert J, et al. *Obstet Gynecol* 2011;117:1105-1113.

Counseling checklist: 3

3. Reassurance on the size of IUS

Holding the IUS is **reassuring** and removes the need for lots of explanation





4. What to expect during placement

LNG IUS can be placed on the day of consultation visit or during a follow-up appointment. Same-day placement may improve utilisation rates as women may not return for a follow-up procedure.

Explain to her how the procedure will work: how long it will take, where it will be, how she will be positioned, etc.

Provide reassurance about the level of discomfort she may experience and that there are measures to reduce this if required.

'Placement can cause a little pain, a bit like period pain, which quickly passes'

'Placement is more painful for some women than others. However, it only takes 5 minutes and provides years of birth control as well as helping with bleeding issues and period pain'



5. Management of pain

- Pre-placement oral analgesia: Although not evidence-based, administration of an NSAID such as ibuprofen 400–600 mg or 1000 mg of paracetamol, 1–2 hours before placement may:
 - Increase women’s confidence and improve their experience
 - Have a placebo effect in terms of minimising pain associated with placement
- Verbal anesthesia and distraction techniques can be helpful to reduce anxiety and may ease potential discomfort
- Intracervical injection of local anesthetic gel: may make cannulation of the cervical canal more comfortable, but clinical evidence for this is limited
- Injectable local anesthesia: no randomised studies have evaluated the impact of pre-placement intracervical or paracervical block on pain associated with IUS placement



6. Possible adverse effects after placement

Discuss potential side effects, such as risk of ectopic pregnancy, perforation, expulsion, infection and changes to monthly bleeding pattern

Discuss the signs/symptoms of these adverse events and their associated risks (e.g. possible loss of fertility after ectopic pregnancy)

Provide context around side effects in relation to other methods of contraception and pregnancy itself

Teach patients to **recognise and immediately report** signs or symptoms of these conditions

Evaluate patients **4–6 weeks after placement** then annually or more often if clinically indicated

7. Effect on bleeding profile after placement

Discontinuation due to bleeding changes can be minimized through counseling and education



Spotting and irregular or heavy bleeding may occur during the first 3–6 months



Cycles may remain irregular, become infrequent, or even cease



Periods may become shorter and/or lighter thereafter, and some women may experience amenorrhea

It is worth noting that rates of amenorrhea reported by women in regular practice may be higher than those reported in clinical trials owing to the strict definitions of amenorrhea used in such studies

LNG IUS SmPC 2019; Gemzell-Danielsson K, et al. *Fertil Steril* 2012;97:616–622.



8. Return to fertility

LNG IUS can be removed at any time and there is a quick return to fertility¹, comparable to that of other LARCs²

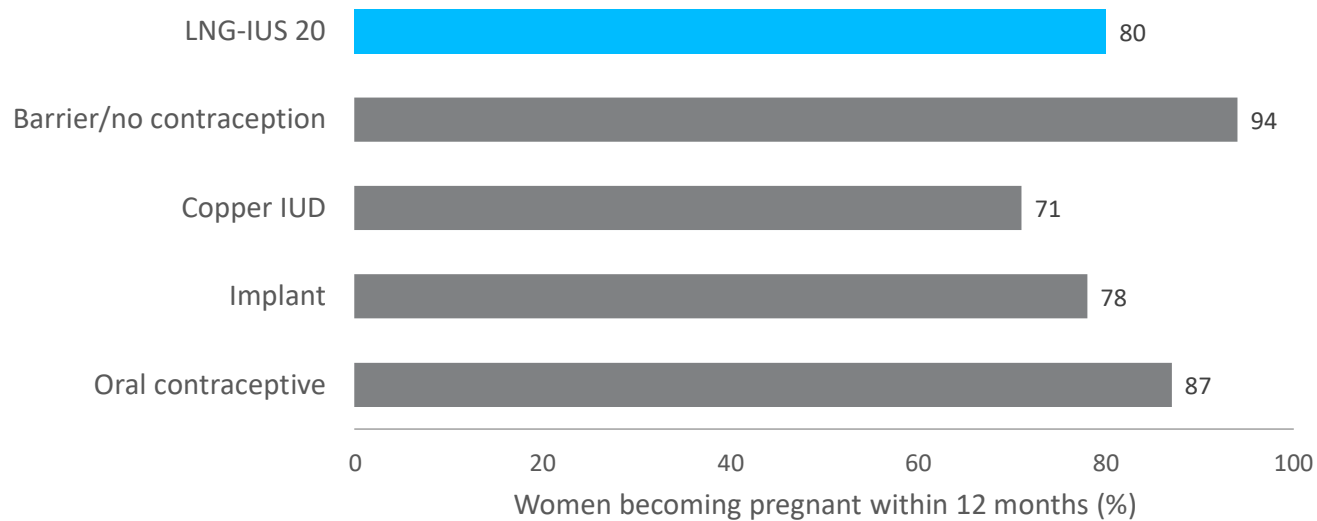

1. Andersson K, et al. *Contraception* 1992; 45: 575–84; 2. Girum T & Wasie A. *Contraception* 2018;3:9.



Scheduling and preparing for LNG IUS placement



Scheduling of the placement procedure

LNG IUS placement is not restricted to during menses. Favorable placement times (no backup contraception required) include^{1,2}:

1st part of cycle
(Within 7 days
of the start
of menstruation)

Immediately after a
first trimester abortion
(medical or surgical)
(within 7 days of
postabortal care)

Minimum of
6 weeks after birth
and after the uterus
has involuted
(if involution is delayed,
consider waiting until
12 weeks postpartum)

Placement can be performed at any point in the menstrual cycle provided the woman^{1,2}:

- Has NOT had unprotected sex (and may be pregnant) since her last menses
- Agrees to continue with her current method of contraception until 7 days after LNG IUS placement

Placement after first trimester abortion is label-approved. However there is evidence to support placement after second trimester abortion as well, although expulsion rates may be higher^{3,4}. It is recommended to wait a minimum of 6 weeks after second trimester abortion or until uterus is fully involuted^{1,2}

1. Mirena Product Monograph 2019; 2. Mirena Prescribing Information; 3. Steenland MW, et al. *Contraception*. 2011;84(5):447–64; 4. Nguyen TNN; WHO. The WHO Reproductive Health Library 2005.



Preparations for LNG IUS placement

- 1 Counsel patient, have her sign the consent form in the Patient Information Booklet, note lot number
- 2 Rule out contraindications (such as acute liver disease or hypersensitivity to levonorgestrel) and pregnancy
- 3 Ensure all equipment required for placement is available to hand
- 4 Perform bimanual exam to assess size/position of uterus
- 5 Perform gynecological/clinical exam to rule out genital contraindications
- 6 Thoroughly cleanse the cervix and vagina
- 7 Sound uterine cavity to assess cavity size and direction
- 8 Open package

Placement of an LNG IUS should only be performed by HCPs with specialist training and experience



1 Counsel patient

Provide specific counseling, as previously described.

Counseling before LNG IUS placement can improve outcomes and increase

satisfaction^{1,2} Psychological preparation may¹:

- Reduce the perception of pain by reducing uncertainty
- Provide information/reassurance on what to expect
- Increase motivation leading to higher tolerance of discomfort

1. Newton JR, Reading AE. *Contraception* 1977;16(5):523–532; 2. Backman T, et al. *Obstet Gynecol* 2002; 99: 608–13.



2 Rule out contraindications and pregnancy ^(1/2)

Take a thorough medical history to rule out contraindications and pregnancy^{1,2}

Pregnancy checklist³

- ✓ Did your last menstrual bleeding start within the past 7 days?
- ✓ Have you abstained from sexual intercourse since your last menstrual bleeding, delivery, abortion or miscarriage?
- ✓ Have you been using a reliable contraceptive method consistently and correctly since your last menstrual bleeding, delivery, abortion or miscarriage?
- ✓ Have you had a baby in the last 4 weeks?
- ✓ Did you have a baby less than 6 months ago, are you fully or nearly-fully breastfeeding, AND have you had no menstrual bleeding since then?
- ✓ Have you had a miscarriage or abortion in the past 7 days?

If she answers **YES** to **at least ONE** of the questions, you can be reasonably certain she is not pregnant

If she answers **NO** to **ALL** of the questions, pregnancy cannot be ruled out using the checklist
Rule out pregnancy using another method

1. WHO Selective Practice Recommendations for Contraceptive Use 2016; 2. US Selective Practice Recommendations for Contraceptive Use 2013;

3. CDC Reasonably Certain Checklist. Available at:

https://www.cdc.gov/reproductivehealth/unintendedpregnancy/pdf/248124_box1_app_b_d_final_tag508.pdf (Accessed March 2021).



3 Ensure equipment for placement is at hand

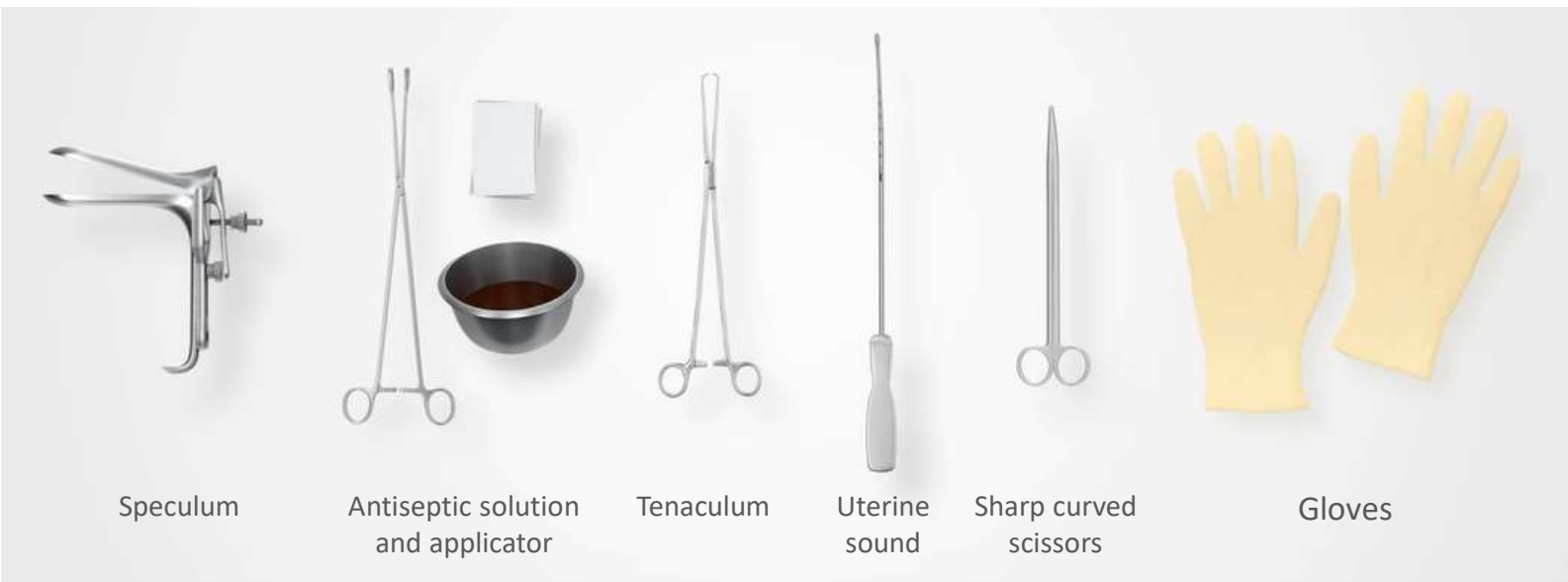

- + LNG IUS with inserter in sealed package
- + Consider having unopened backup IUS

Mirena Prescribing Information.

4 Perform bimanual exam to assess size and position of uterus

With the individual comfortably in lithotomy position, do a bimanual exam to establish the size, shape and position of the uterus

Gently insert a speculum to visualise the cervix



Good visualisation and lighting are important

Techniques for assisting lateral retraction when there is obstruction to visualisation:

- Ring forceps opened to laterally push the vaginal walls with the speculum in place
- A sidewall retractor device
- A condom with the end cut off placed over the top of the speculum





5 Perform gynecological/clinical exam to rule out contraindications

The gynecological/clinical exam should aim to exclude:

- Uterine abnormalities
- Pelvic inflammatory disease
- Pregnancy

LNG IUS placement can be performed without the need for cervical priming in the majority women

- Analgesics, paracervical block or cervical dilatation could be considered in selected cases
- Use of misoprostol for the sole purpose of reducing placement-related pain is not evidence-based¹

Misoprostol may be useful to facilitate ease of placement in **selected cases** where the cervical canal is particularly tight and/or resistant to cervical dilation (e.g. some nulliparous women, women with cervical stenosis)

- Vaginal administration of misoprostol 4-8 hours before IUS placement is preferable to sublingual - more effective, less uterine cramping
- An **NSAID should always be given if misoprostol is used**, to minimise misoprostol-induced uterine cramping

1. Matthews LR, et al. *Obstet Gynecol.* 2016;128(5):1084–91.



6 Thoroughly cleanse the cervix and vagina

If choosing to cleanse the cervix and vagina, make sure a suitable antiseptic solution is used:

- Povidone-iodine is most commonly used
- Chlorohexidine may be used if the patient is allergic to iodine

Cleaning the cervix and vagina is not evidence-based¹⁻³, but some providers believe it is:

- Good defensive practice
- Reassuring to women

1. Tolcher R. *J Fam Plann Reprod Health Care*. 2003 Jan;29(1):21–4; 2. Penney G, et al. *J Fam Plann Reprod Health Care*. 2004 Jan;30(1):29–41; 3. FSRH Clinical Guidance 2019. Available at: <https://www.fsrh.org/standards-and-guidance/documents/ceuguidanceintrauterinecontraception/> (Accessed March 2020).

7 Sound uterine cavity to assess cavity size and direction (1/2)

The uterus should be sounded before LNG IUS placement

Grasp the upper lip of the cervix with tenaculum forceps and gently apply traction to stabilise and align the cervical canal with the uterine cavity. The tenaculum should remain in position and gentle traction on the cervix should be maintained throughout the placement procedure

NOTE: If the uterus is sharply anteverted or retroverted, it may be more appropriate to grasp the lower lip of the cervix. A pillow or other material may also be placed under the hips to change the angle of the pelvis and suprapubic pressure can be applied. If available, ultrasound may be used to guide insertion



Gentle traction to stabilise and align cervical canal with uterine cavity



7 Sound uterine cavity to assess cavity size and direction (2/2)

Gently insert a uterine sound

Check the patency of the cervix, measure the depth of the uterine cavity in centimeters, confirm cavity direction, and detect the presence of any uterine anomaly

- If you encounter difficulty or cervical stenosis, use dilatation, not force, to overcome resistance
- If cervical dilatation is required, consider using a paracervical block



Dilatation is **not required** in most cases, even in nulliparous women with tighter cervical canals

Dilatation should not be performed routinely as cervical stretching increases risk of vasovagal reactions

Mirena Prescribing Information.



Placement procedure



LNG IUS is inserted using the EvoInserter

Components of LNG IUS, including its packaging do not contain any natural rubber latex

4.4 mm insertion tube diameter

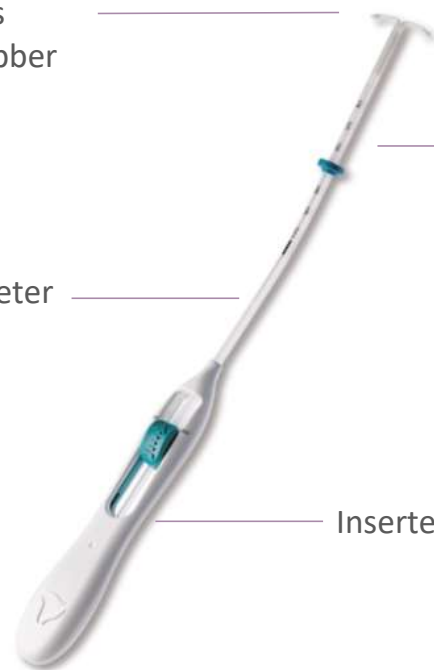

T-body arms in ready-to-load position

Threads contained within insertion tube handle

Inserter design allows single handed placement



Placement procedure steps

- Step 1 Open the sterile packaging completely
- Step 2 Load the LNG IUS into the insertion tube
- Step 3 Set the flange
- Step 4 Introduce the insertion tube
- Step 5 Deploy the side arms. Wait 10 sec
- Step 6 Advance to fundal position
- Step 7 Release the LNG IUS and withdraw the inserter.
- Step 8 Cut the threads (about 3cm outside cervix)

Step 1: Open the sterile packaging completely

Step 1

Open the sterile packaging

The contents of the package are sterile

Using sterile gloves lift the handle of the sterile inserter and remove from the sterile package

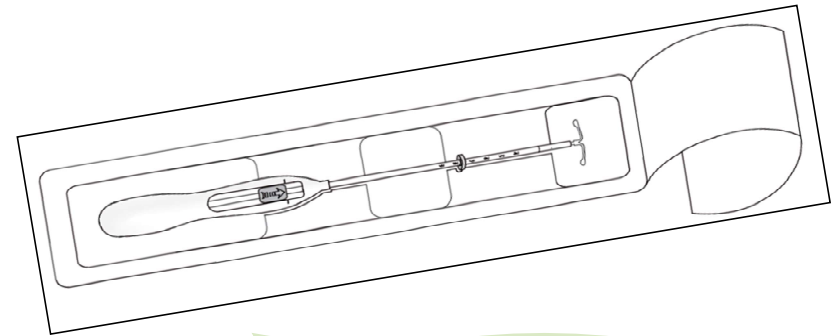

Note:

- Single-use only
- Do not re-sterilise
- Check expiry date and do not use after expiry

Step 2: Load the IUS into the insertion tube

Step 2

Load the LNG IUS into the insertion tube

Push the slider **forward** as far as possible in the direction of the arrow thereby moving the insertion tube over the T-body to load the IUS into the insertion tube. The tips of the arms will meet to form a rounded end that extends slightly beyond the insertion tube

Maintain forward pressure with thumb or forefinger on the slider

IMPORTANT



DO NOT move the slider downward at this time as this may prematurely release the threads of the IUS. Once the slider is moved below the mark, the **LNG IUS cannot be reloaded**

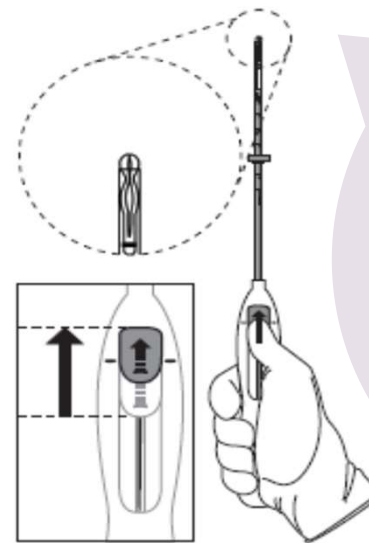

Note:

- The arrow on the slider indicates the direction of the loading movement
- Preparation only requires one step: push the cursor towards the top of the handle in the direction of the arrow until the end to bring the IUS into the insertion tube



Step 3: Set the flange

Step 3

Set the flange

Holding the slider in this forward position, set the upper edge of the flange to correspond to the uterine depth (in centimeters) measured during sounding

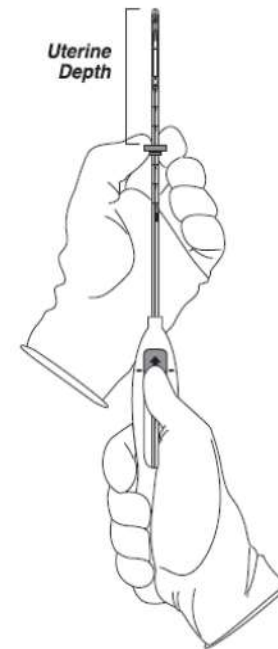

Step 4: Introduce the insertion tube

Step 4

The IUS is ready for placement

Continue holding the slider in this forward position. Advance the inserter through the cervix until the flange is approximately 1.5 to 2 cm from the cervix and then pause

IMPORTANT

 Do not force the inserter. If necessary, dilate the cervical canal

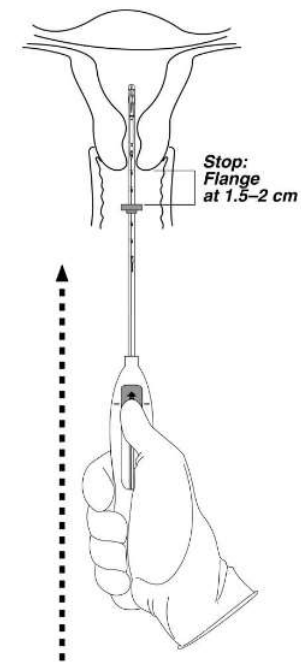



Step 5: Deploy the side arms

Step 5

Open the arms

While holding the inserter steady, **move the slider down** to the mark to release the arms of the IUS

Wait 10 seconds for the horizontal arms to open completely!

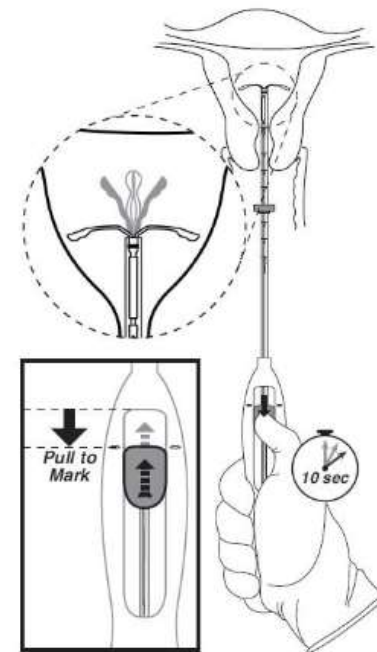

Step 6. Advance to fundal position

Step 6

Advance to fundal position

Without touching the slider, advance the inserter gently towards the fundus of the uterus **until the flange touches the cervix**

If you encounter fundal resistance **do not** continue to advance

LNG IUS is now in the fundal position

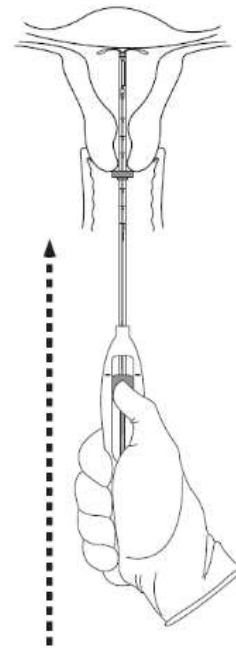

Note:
Fundal positioning of LNG IUS is important to prevent expulsion



Step 7: Release LNG IUS

Step 7

Release LNG IUS and withdraw the inserter

Holding the entire inserter in place, release the IUS by moving **the slider all the way down (toward you)**

Continue to hold the slider all the way down while you slowly and gently withdraw the inserter from the uterus

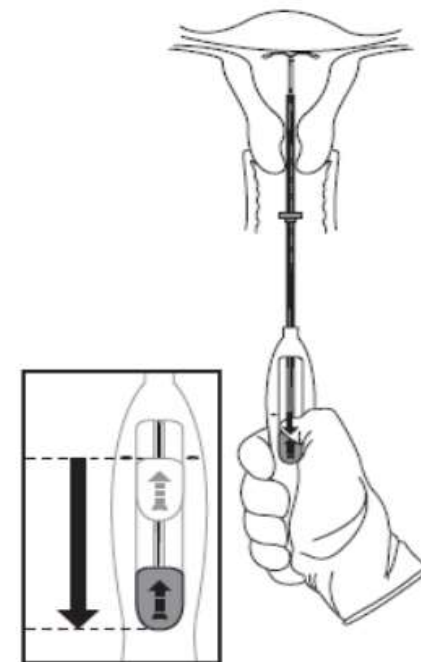

Step 8: Cutting the threads

Step 8

Using sharp, curved scissors, cut the threads perpendicular, leaving about 3 cm visible outside the cervix (cutting threads at an angle may leave sharp ends). This will:

- Minimise any perception by the male partner during sexual intercourse
- Ensure that the threads can be found when the device comes to be removed

Do not apply tension or pull on the threads when cutting to prevent displacing LNG IUS

Placement is now complete

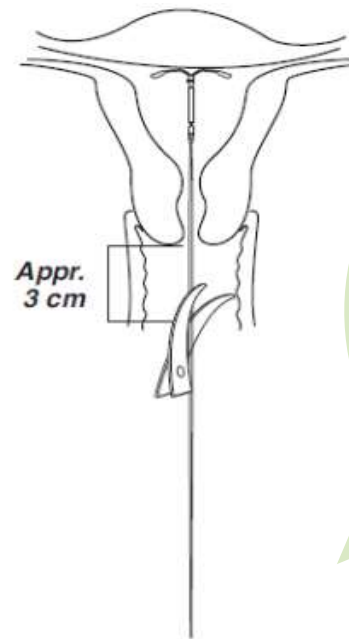

Ensure that both threads have been cut rather than just one, to avoid the device/system being pulled out through the cervix as the 'cut' threads are pulled away



Post-placement and LNG IUS removal



Post-placement checklist

Post-placement checklist

- ✓ Record lot number
- ✓ Reassure woman regarding potential bleeding pattern during first months
- ✓ Advise that she can return to the clinic if she has any concerns
- ✓ Prescribe analgesics if indicated
- ✓ Counsel woman on how to check the threads
- ✓ Inform her that intercourse and careful use of tampons/menstrual cups are possible after placement

If there is clinical concern, exceptional pain or bleeding during or after placement, appropriate steps (e.g. physical examination and ultrasound) should be taken immediately to exclude perforation

Woman should be advised to be careful to avoid getting the IUS threads caught when removing tampon/menstrual cup. Checking threads after removal should be recommended



Post-placement considerations

Be alert to the possibility of vasovagal effects (which can occur during or after the placement procedure)

Inform women that vasovagal effects are normal to minimise anxiety should they occur

After the speculum is removed the woman should remain lying down for a short period and then sitting for a short period to allow any possible vasovagal effect to pass

Post-placement analgesia is not necessary in most cases

In those women who experience pain after the procedure, oral analgesia that they would normally take for menstrual cramps may be recommended



Removal and replacement of LNG IUS

Women should be advised to have their IUS removed when it is no longer effective or desired

LNG IUS should be removed/replaced if:

- The maximum duration of use has been reached
- The woman has contraindications to device use (e.g. adverse events)
- The woman no longer desires the device

The maximum period of use is 8 years for LNG IUS

If pregnancy is not desired and the woman wishes to continue with IUS use, the device should be removed and a new device should be placed immediately. If the woman wishes to switch to another method of contraception, begin this method 7 days prior to IUS removal (if possible).

Return to fertility is not impacted by IUS use.



Removal and replacement

Removal

To remove, pull the wires with forceps

After removal, inspect the system to verify that it is intact

The IUS must be removed during the first 7 days of menstruation if menstrual cycles persist

Use sonography to help if no strings visible (specific forceps usually allow recovery in the uterine cavity after echo display)

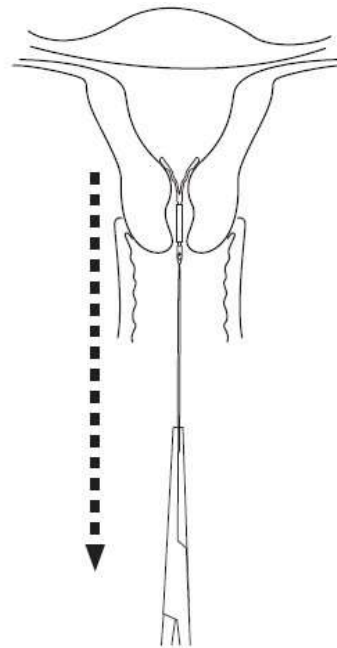

Replacement

A new IUS can be placed immediately after withdrawal of the used one



Frequently asked questions

What is the expulsion rate for LNG IUS?



The reported cumulative expulsion rate for LNG IUS at 1 year varies between 1% and 3.7%; this decreases to 1.6% at 3 years. Risk factors include young age or uterine abnormalities

Summary of evidence

Cumulative gross expulsion rate for LNG IUS (n=1821 women) at 1 year was 3.7 per 100 women. The monthly cumulative expulsion rates indicate that expulsions occurred with equal frequency over the 12-month period. Expulsion rate declined with increasing age and/or parity.¹

Net cumulative expulsion rate for LNG IUS (n=1821) ranged from 3.4 per 100 women in year 1 to 4.9 in year 5.²

Expulsion rates after 12 months were similar in the LNG IUS (n≈42,000) and Cu-IUD (n≈18,000) populations: 1.0% and 1.2%, respectively.^{3,4}

Risk factors for expulsion include heavy menstrual bleeding, dysmenorrhea, young age, adenomyosis, leiomyoma, and previous expulsion.⁵⁻⁷ Low parity may be a risk factor but evidence for this is conflicting.^{1,5}

1. Luukkainen T, et al. *Contraception*. 1987; 36(2): 169–79; 2. Andersson K, Odland V, Rybo G. *Contraception*. 1994; 49:56–72; 3. Heinemann K, et al. *Contraception*. 2015; 91(4):280–3; 4. Data on file. European Active Surveillance Study for Intrauterine Devices (EURAS-IUD); 5. Madden T, et al. *Obstet Gynecol*. 2014; 124:718–26; 6. Youm J, et al. *Int J Gynaecol Obstet*. 2014; 126(2):165–9; 7. Merki-Feld GS, et al. *Eur J Obstet Gynecol Reprod Biol*. 2008; 137(1):92–6.

What age group experiences LNG IUS expulsion the most? Is the expulsion rate affected by age?



Cumulative expulsion rates may be higher in adolescents and young women (aged 13–25 years) although some studies have found no difference between age groups

Summary of evidence

The cumulative rate of expulsion is higher in females aged 14–19 years than among older women (18.8 vs 9.3 per 100 women, respectively; $P < 0.001$). After adjusting for confounders and stratifying by IUC type, the hazard ratio for expulsion of LNG IUS for females aged 14–19 years is 2.26 (95% CI 1.68–3.06).¹

Another study found no significant differences in overall expulsion rates among age groups (13–19, 20–24 and 25–35 years). Adolescents and young women aged 13–19 years were more likely to have partial expulsion (60%) than were the two older cohorts.²

The variables significantly associated with an expulsion of LNG IUS were age < 25 years and fewer than two deliveries.³

1. Madden T, et al. *Obstet Gynecol.* 2014;124(4):718–26; 2. Aoun J, et al. *Obstet Gynecol.* 2014;123(3):585–92; 3. Simonatto P, et al. *J Obstet Gynaecol Res.* 2016;42(5):554–9.

When LNG IUS is found to be low within the uterine cavity, is efficacy compromised?



Fundal positioning of LNG IUS is important to reduce risk of expulsion. Evidence for the efficacy of malpositioned devices is conflicting and minimal

Summary of evidence

Fundal positioning of LNG IUS is important in order to reduce the risk of expulsion. However, there is no evidence defining the allowable distance from the fundus to ensure maximum safety and efficacy for LNG IUS.¹

In one study, over half of the women who had become pregnant while using an IUC had malpositioned device (n=42).²

In another study of women with malpositioned IUC (n=182), no pregnancies occurred with the device in situ.³

The position of LNG IUS did not influence pain scores or bleeding patterns (n=413) suggesting these symptoms are not reliable predictors of malpositioning.⁴

The efficacy of LNG IUS may be less affected by its position in the uterine cavity than is a Cu-IUD, because of the local release of progestogen. Placement of LNG IUS in the cervical canal did not increase risk of pregnancy relative to placement in the uterine cavity.⁵

1. Mirena Product Monograph. Bayer Inc., Mississauga, Ontario. June 14, 2019; 2. Moschos E, Twickler DM. *Am J Obstet Gynecol.* 2011; 204: 427.e1–e.6; 3. Braaten KP, et al. *Obstet Gynecol.* 2011;118(5):1014–20; 4. Van Schoubroeck D, et al. *Eur J Obstet Gynecol Reprod Biol.* 2013; 171(1):154–6; 5. Pakarinen P, Luukkainen T. *Contraception.* 2005;72(5):342–5.



Should a malpositioned LNG IUS be repositioned or removed?



Repositioning is often successful but may be painful or uncomfortable for the woman. A partially expelled device should be removed. A device may be left in place if it remains above the external os AND the woman is experiencing no symptoms.

Summary of evidence

After repositioning malpositioned LNG IUS using alligator forceps (and confirmation of correct position with transvaginal ultrasound), patients described pain similar to that experienced with the initial placement. The procedure was successful in 17 (94.4%) of 18 cases. After repositioning, 3/17 (17.6%) were malpositioned again within 3 months.¹

Malpositioned LNG IUS were correctly relocated in 99.1% cases (112/113 women) by hysteroscopic intervention. After repositioning, two patients (1.8%) experienced expulsion.²

ACOG recommendation: "Management of the nonfundal IUC varies depending upon the position of the device and the patient's symptoms. An IUC located within the cervix is partially expelled; given the increased risk of complete expulsion, the IUC should be removed (and replaced if the patient desires). If the woman is asymptomatic and the IUC is above the external os, removal of the IUC is more likely to lead to pregnancy than IUC retention."³

If device is removed, immediate replacement or alternative contraception should be used.^{2,4}

ACOG= American College of Obstetricians and Gynecologists

1. Ber A, Seidman DS. *Contraception*. 2012;85:369–73; 2. Kuzel D, et al. *J Obstet Gynaecol Res* 2013;39:1014–18; 3. ACOG. Clinical Challenges of Long-Acting Reversible Contraceptive Methods. Committee Opinion No. 672, September 2016; 4. Braaten KP, et al. *Obstet Gynecol*. 2011;118:1014–20.